

DRO



Multi-channel open impeller

General characteristics

Multi-channel open impeller	
motor power	0,37 ÷ 1,5 kW
poles	2
delivery port	GAS 1 1/4" - 2" vertical GAS 2" - DN50 horizontal
free passage	max 15 mm
max flow rate	13.0 l/s
max head	18.4 m

Electromechanical assembly

Electromechanical assembly in GJL-250 cast iron, for submerged operation. Seal set comprising 1 (one) silicon carbide mechanical seal and 1 (one) graphite alumina mechanical seal, installed opposing with oil lubrication. Oil bath motor.

Applications

Can be used with clear or slightly soiled wastewaters containing small solids, strained water, rainwater, seepage and water pumped from underground. Suitable for heavy-duty domestic and professional applications

Construction materials

Case	Cast iron EN-GJL 250
Impeller	Cast iron EN-GJL-250
Nuts and bolts	Stainless steel - Class A2-70
Standard gasket	Rubber - NBR
Shaft	Stainless steel - AISI 420
Paint type	Ecological bicomponent epoxy (medium thickness 80 µm)
Set of standard mechanical seals	One silicon carbide mechanical seal (SiC) and one carbon-aluminium oxide mechanical seal (AL)

Operating limits

Maximum operating temperature	40 °C
PH of treated fluid	6 ÷ 11
Viscosity of treated fluid	1 mm ² /s
Maximum immersion depth	20 m
Density of treated fluid	1 Kg/dm ³
Maximum acoustic pressure	70 dB
max starts per hour	20

DRO



Handle
AISI 304 stainless steel lifting and carrying handle



Structure
Constructed in cast iron

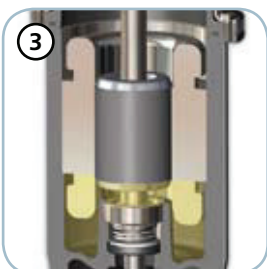

Motor
Oil bath motor with thermal protections. Capacitor and overload protection in external cabinet.



Mechanical seals
One mechanical seal in silicon carbide (SiC) and one mechanical seal in alumina graphite (AL)



Anti-clogging system
The special design of the hydraulic part ensures the expulsion of suspended solids and prevents fouling of the impeller



Intake strainer
Intake strainer in stainless steel

DRO

Models with vertical GAS 1 1/4" threaded delivery port - 2 poles

Performances

	l/s	0	1	2	3	4	5	6
	l/min	0	60	120	180	240	300	360
	m ³ /h	0	3.6	7.2	10.8	14.4	18.0	21.6
①	DRO 50/2/G32V A0CM(T)/50	8.8	8.1	6.9	5.2	2.7		
②	DRO 75/2/G32V A0CM(T)/50	12.1	11.8	10.8	9.1	6.9	4.2	0.9

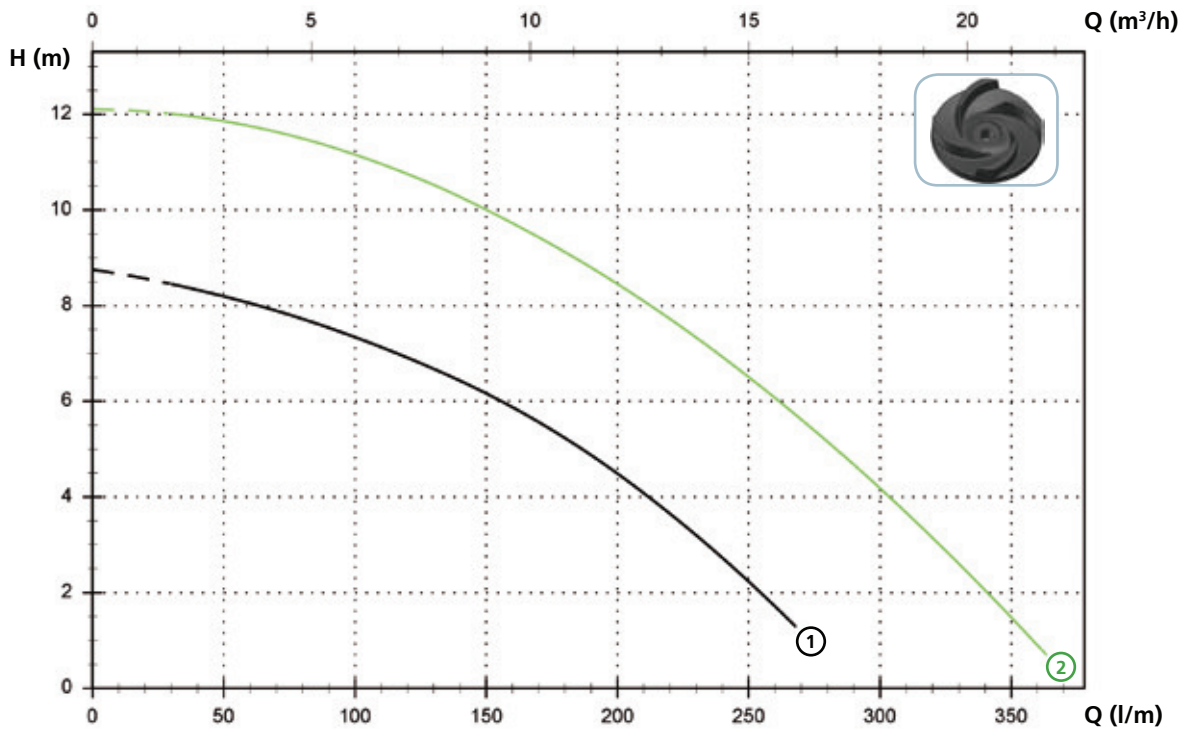

Technical data

	V	Phases	P1 (kW)	P2 (kW)	A	Rpm	Start	Ø	Cable (*)	Free passage	
①	DRO 50/2/G32V A0CM/50	230	1	-	0.37	2.9	2900	Dir	G 1 1/4"	A	15 mm
②	DRO 75/2/G32V A0CM/50	230	1	-	0.55	3.9	2900	Dir	G 1 1/4"	A	15 mm
	V	Phases	P1 (kW)	P2 (kW)	A	Rpm	Start	Ø	Cable (*)	Free passage	
①	DRO 50/2/G32V A0CT/50	400	3	-	0.37	1.1	2900	Dir	G 1 1/4"	A	15 mm
②	DRO 75/2/G32V A0CT/50	400	3	-	0.55	1.4	2900	Dir	G 1 1/4"	A	15 mm

(*) A = H07RN-F 4G1 - 5 m cable length. Optional 10 m cable length

Attention: Standard EN 60335-2-41 requires the use of a 10 m cable length in outdoor applications

Models with vertical GAS 2" threaded delivery port - 2 poles

Performances

	l/s	0	2	4	6	8	10	12
	l/min	0	120	240	360	480	600	720
	m ³ /h	0	7.2	14.4	21.6	28.8	36.0	43.2
①	DRO 100/2/G50V A0CM(T)/50	12.4	11.5	10.0	7.9	5.0	1.1	
②	DRO 150/2/G50V A0CM(T)/50	16.3	15.2	13.8	11.9	9.3	6.0	2.1
③	DRO 200/2/G50V A0CM(T)/50	18.4	17.1	15.6	13.9	11.7	8.6	4.5

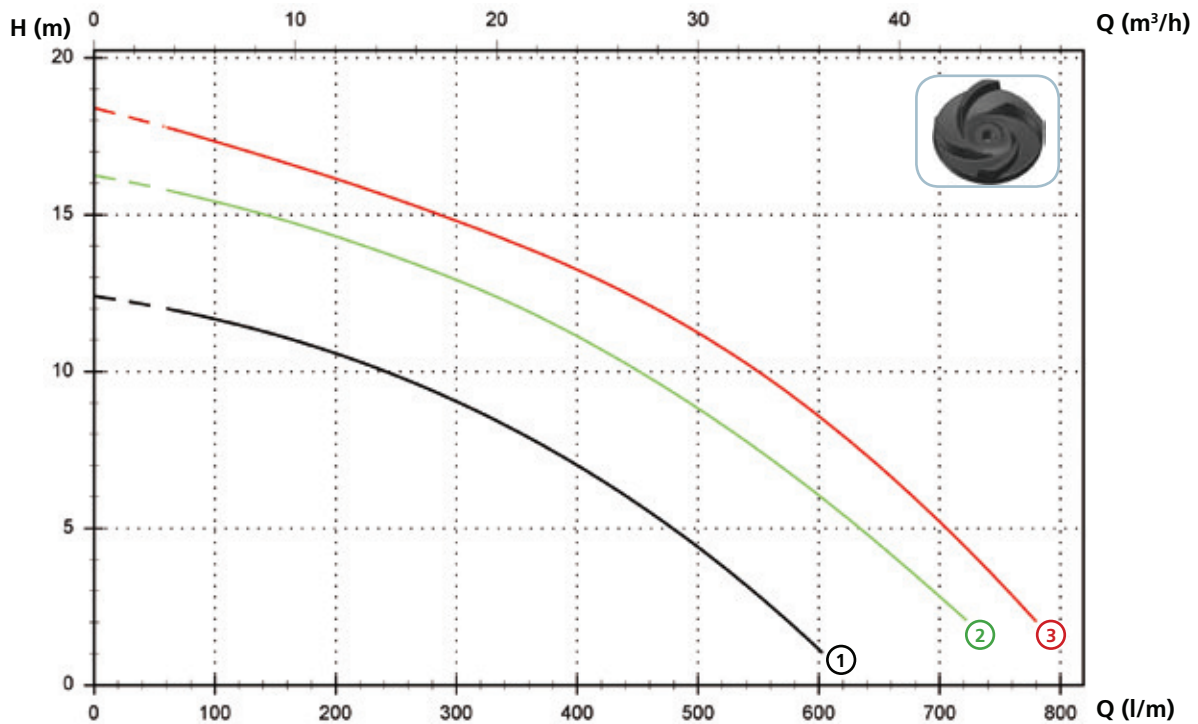

Technical data

	V	Phases	P1 (kW)	P2 (kW)	A	Rpm	Start	Ø	Cable (*)	Free passage	
①	DRO 100/2/G50V A0CM/50	230	1	-	0.88	6.5	2900	Dir	G 2"	A	15 mm
②	DRO 150/2/G50V A0CM/50	230	1	-	1.1	8.2	2900	Dir	G 2"	A	15 mm
③	DRO 200/2/G50V A0CM/50	230	1	-	1.5	9.3	2900	Dir	G 2"	A	15 mm

	V	Phases	P1 (kW)	P2 (kW)	A	Rpm	Start	Ø	Cable (*)	Free passage	
①	DRO 100/2/G50V A0CT/50	400	3	-	0.88	2.3	2900	Dir	G 2"	A	15 mm
②	DRO 150/2/G50V A0CT/50	400	3	-	1.1	2.7	2900	Dir	G 2"	A	15 mm
③	DRO 200/2/G50V A0CT/50	400	3	-	1.5	3.5	2900	Dir	G 2"	A	15 mm

(*) A = H07RN-F 4G1 - 5 m cable length. Optional 10 m cable length
 Attention: Standard EN 60335-2-41 requires the use of a 10 m cable length in outdoor applications

DRO

Models with horizontal GAS 2" threaded - DN50 PN10-16 flanged delivery port - 2 poles

Performances

	l/s	0	2	4	6	8	10	12
	l/min	0	120	240	360	480	600	720
	m ³ /h	0	7.2	14.4	21.6	28.8	36.0	43.2
①	DRO 100/2/G50H A0CM(T)/50	12.4	11.5	10.0	7.9	4.9		
②	DRO 150/2/G50H A0CM(T)/50	16.3	15.2	13.8	11.9	9.3	6.0	
③	DRO 200/2/G50H A0CM(T)/50	18.4	17.1	15.6	13.9	11.7	8.6	4.5

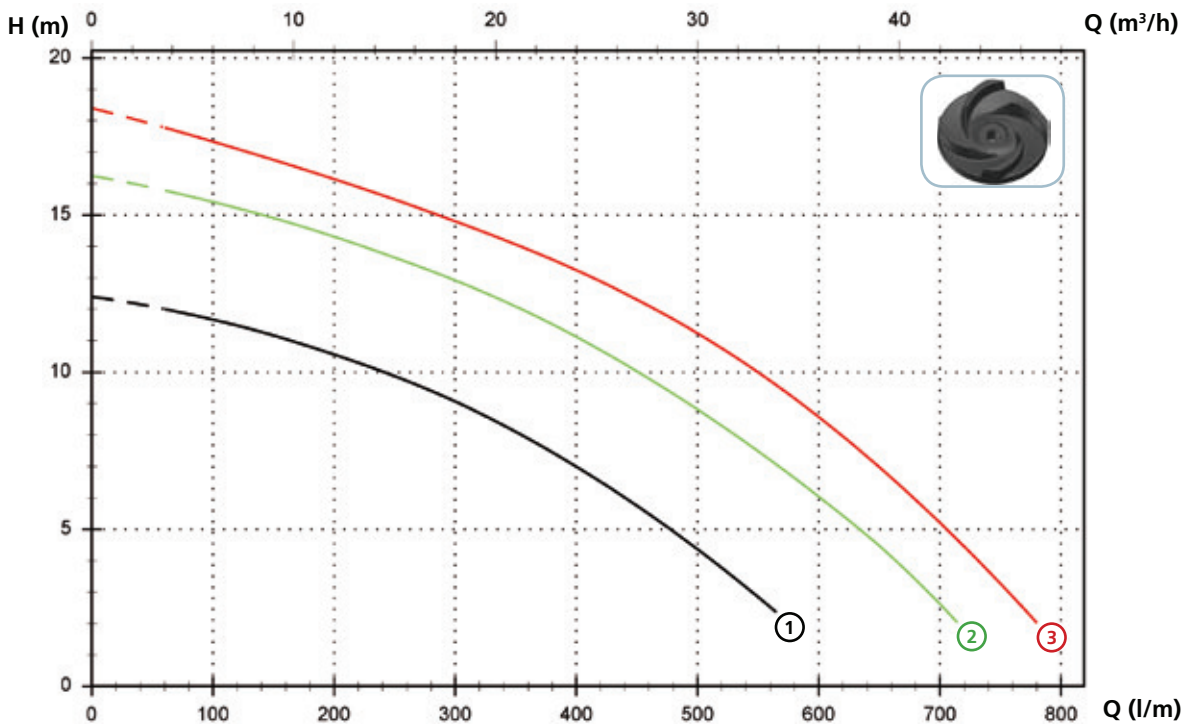

Technical data

	V	Phases	P1 (kW)	P2 (kW)	A	Rpm	Start	Ø	Cable (*)	Free passage	
①	DRO 100/2/G50H A0CM/50	230	1	-	0.88	6.5	2900	Dir	G 2"- DN50 PN10-16	A	15 mm
②	DRO 150/2/G50H A0CM/50	230	1	-	1.1	8.2	2900	Dir	G 2"- DN50 PN10-16	A	15 mm
③	DRO 200/2/G50H A0CM/50	230	1	-	1.5	9.3	2900	Dir	G 2"- DN50 PN10-16	A	15 mm
	V	Phases	P1 (kW)	P2 (kW)	A	Rpm	Start	Ø	Cable (*)	Free passage	
①	DRO 100/2/G50H A0CT/50	400	3	-	0.88	2.3	2900	Dir	G 2"- DN50 PN10-16	A	15 mm
②	DRO 150/2/G50H A0CT/50	400	3	-	1.1	2.7	2900	Dir	G 2"- DN50 PN10-16	A	15 mm
③	DRO 200/2/G50H A0CT/50	400	3	-	1.5	3.5	2900	Dir	G 2"- DN50 PN10-16	A	15 mm

(*) A = H07RN-F 4G1 - 5 m cable length. Optional 10 m cable length
 Attention: Standard EN 60335-2-41 requires the use of a 10 m cable length in outdoor applications

Versions available

(Key to versions on page 16)

	Electrical variants											Cooling				Mechanical seals				
	N A E	T	T C	T C D	T C D T	T C D G T	T C G	T C S T	T C S G T	T S	T R	T R G	N	CC CCE	FT	C G F T	2SIC	SICM	SICAL	2SICAL
DRO 50/2/G32V A0CM/50		●						●	●			●							●	
DRO 75/2/G32V A0CM/50		●						●	●			●							●	
DRO 100/2/G50V A0CM/50		●						●	●			●							●	
DRO 150/2/G50V A0CM/50		●						●	●			●							●	
DRO 200/2/G50V A0CM/50		●						●	●			●							●	
DRO 100/2/G50H A0CM/50		●						●	●			●							●	
DRO 150/2/G50H A0CM/50		●						●	●			●							●	
DRO 200/2/G50H A0CM/50		●						●	●			●							●	
DRO 50/2/G32V A0CT/50	●											●							●	
DRO 75/2/G32V A0CT/50	●											●							●	
DRO 100/2/G50V A0CT/50	●											●							●	
DRO 150/2/G50V A0CT/50	●											●							●	
DRO 200/2/G50V A0CT/50	●											●							●	
DRO 100/2/G50H A0CT/50	●											●							●	
DRO 150/2/G50H A0CT/50	●											●							●	
DRO 200/2/G50H A0CT/50	●											●							●	

Overall dimensions and weights

Models with vertical delivery port

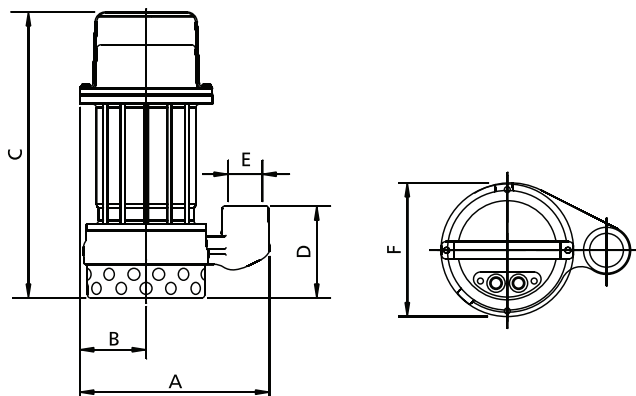

	A	B	C	D	E	F	kg
DRO 50/2/G32V A0CM(T)/50	220	75	330	105	G 1 1/4"	155	15
DRO 75/2/G32V A0CM(T)/50	220	75	330	105	G 1 1/4"	155	15.5
DRO 100/2/G50V A0CM(T)/50	260	95	385	125	G 2"	195	19.5
DRO 150/2/G50V A0CM(T)/50	260	95	385	125	G 2"	195	20.5
DRO 200/2/G50V A0CM(T)/50	260	95	385	125	G 2"	195	21.5

Measurements in mm

DRO

Models with horizontal discharge

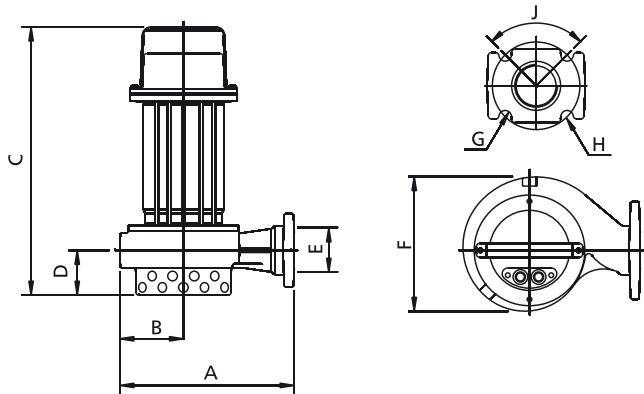

	A	B	C	D	E	F	G	H	J	kg
DRO 100/2/G50H A0CM(T)/50	250	90	385	65	G 2"-DN50	195	18	125	90°	19.5
DRO 150/2/G50H A0CM(T)/50	250	90	385	65	G 2"-DN50	195	18	125	90°	20.5
DRO 200/2/G50H A0CM(T)/50	250	90	385	65	G 2"-DN50	195	18	125	90°	21.5

Dimensions in mm

All weights and dimensions are indicative only

Packaging dimension

	A	B	C
DRO 50/2/G32V A0CM(T)/50	385	225	245
DRO 75/2/G32V A0CM(T)/50	385	225	245
DRO 100/2/G50V A0CM(T)/50	475	285	235
DRO 150/2/G50V A0CM(T)/50	475	285	235
DRO 200/2/G50V A0CM(T)/50	475	285	235
DRO 100/2/G50H A0CM(T)/50	475	285	235
DRO 150/2/G50H A0CM(T)/50	475	285	235
DRO 200/2/G50H A0CM(T)/50	475	285	235

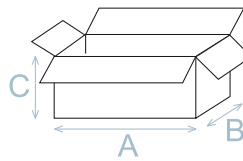

Dimension in mm

All weights and dimensions are indicative only

No. pieces per pallet

For DRO 50-75 models each pallet (EUR 1000x1200 mm) is able to take 48 pieces.

For DRO 100-150-200 models each pallet (EUR 1000x1200 mm) is able to take 32 pieces.

Installations available

