

DGX



Special alloy pumps

General characteristics

Special alloy pump	
motor power	0,37 ÷ 1,5 kW
poles	2 / 4
delivery port	GAS 2" vertical DN65 - DN80 horizontal
free passage	max 60 mm
max flow rate	18.4 l/s
max head	14.9 m

Electromechanical assembly

Electromechanical assembly in CF-8M (AISI 316) stainless steel, for submerged operation. Seal set comprising 2 (two) silicon carbide mechanical seals assembled opposing and with oil lubrication. Oil bath motor.

Applications

Ideal for lifting strongly corrosive or aggressive strained liquids, especially in the chemical industry. Intended for specific industrial applications.

Construction materials

Case	Cast stainless steel - CF-8M (AISI 316)
Impeller	Stainless steel
Nuts and bolts	Stainless steel - Class A4-70
Standard gasket	Rubber - VITON
Shaft	Stainless steel - AISI 316
Set of standard mechanical seals	Two silicon carbide mechanical seals (2SiC)

Operating limits

Maximum operating temperature	40 °C
PH of treated fluid	5 ÷ 10
Viscosity of treated fluid	1 mm ² /s
Maximum immersion depth	20 m
Density of treated fluid	1 Kg/dm ³
Maximum acoustic pressure	70 dB
max starts per hour	20

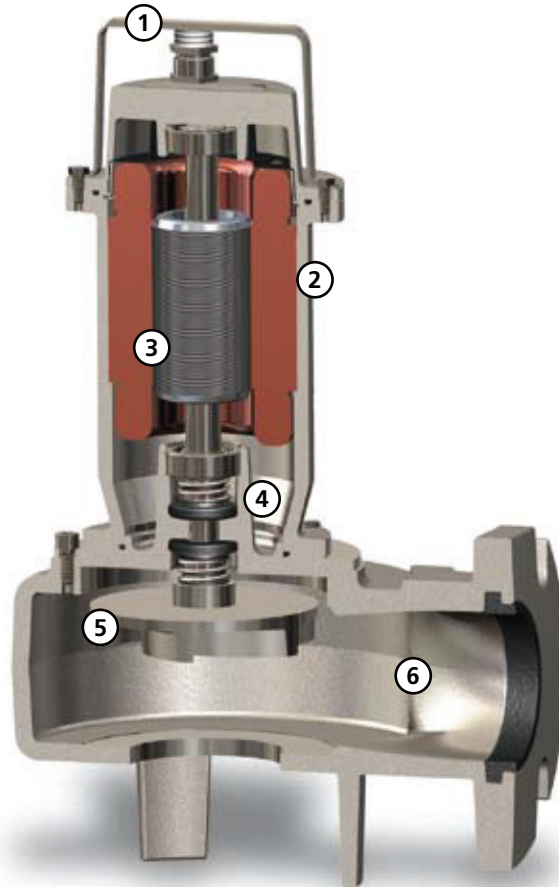

Handle and cable gland

AISI 316 stainless steel lifting and carrying handle. A rigid or flexible duct can be fixed to the cable gland to protect the power supply cable



Structure

CF-8M steel construction which makes the pump suitable for use in saline environments

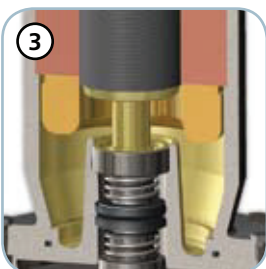

Motor

Oil-bath motor with thermal protections



Mechanical seals

Two mechanical seals in silicon carbide (2SiC)



Impeller

Vortex impeller in CF-8M steel

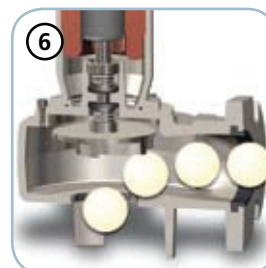

Free passage

Wide free passage allowing the expulsion of solids and preventing fouling of the impeller

DGX

Models with vertical GAS 2" threaded delivery port - 2 poles

Performances

	l/s	0	1	2	3	4	5	6	7	8	9	10
	l/min	0	60	120	180	240	300	360	420	480	540	600
	m ³ /h	0	3.6	7.2	10.8	14.4	18.0	21.6	25.2	28.8	32.4	36.0
①	DGX 50/2/G50V A0CM(T)/50	7.6	6.5	5.4	4.3	3.2	2.1					
②	DGX 75/2/G50V A0CM(T)/50	8.4	7.4	6.3	5.3	4.3	3.3	2.4				
③	DGX 100/2/G50V A0CM(T)/50	12.1	11.1	10.0	8.9	7.8	6.7	5.4	4.2	2.9		
④	DGX 150/2/G50V A0CM(T)/50	13.9	12.8	11.7	10.6	9.4	8.2	7.0	5.8	4.6	3.3	
⑤	DGX 200/2/G50V A0CM(T)/50	14.9	13.7	12.6	11.5	10.3	9.1	7.9	6.7	5.5	4.2	2.9

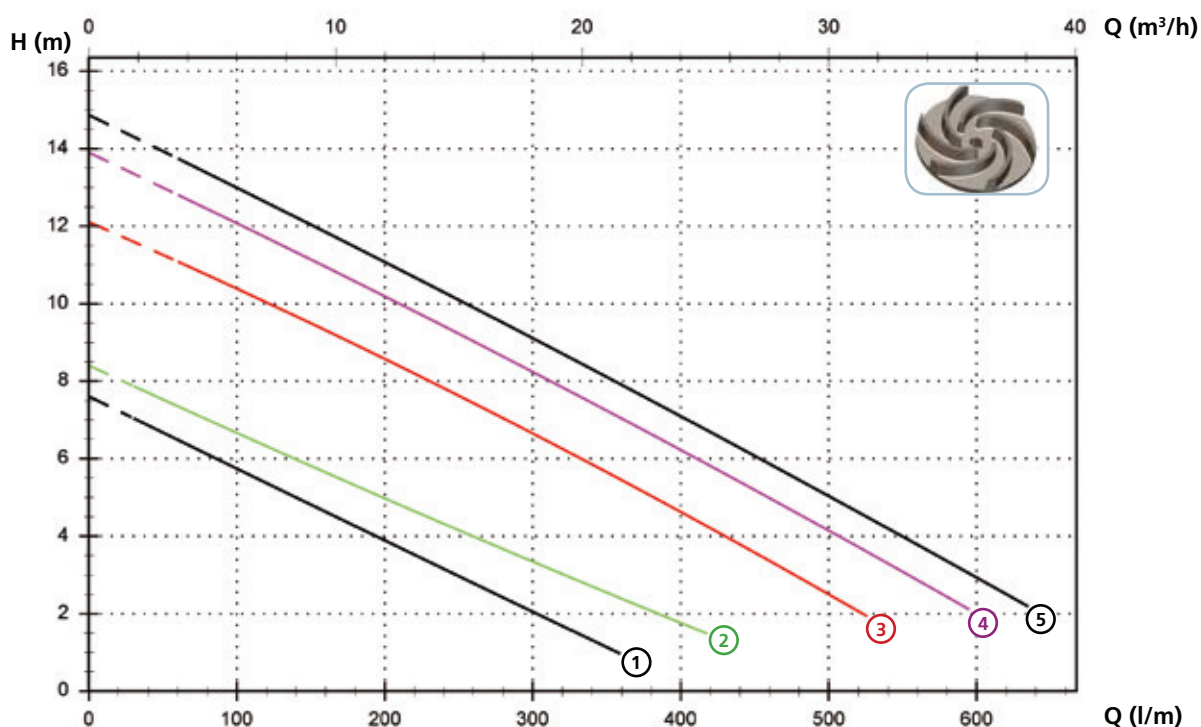

Technical data

	V	Phases	P1 (kW)	P2 (kW)	A	Rpm	Start	Ø	Cable (*)	Free passage	
①	DGX 50/2/G50V A0CM/50	230	1	-	0.37	2.9	2900	Dir	G 2"	A	38 mm
②	DGX 75/2/G50V A0CM/50	230	1	-	0.55	3.9	2900	Dir	G 2"	A	38 mm
③	DGX 100/2/G50V A0CM/50	230	1	-	0.88	6.5	2900	Dir	G 2"	A	38 mm
④	DGX 150/2/G50V A0CM/50	230	1	-	1.1	8.2	2900	Dir	G 2"	A	38 mm
⑤	DGX 200/2/G50V A0CM/50	230	1	-	1.5	9.3	2900	Dir	G 2"	A	38 mm

	V	Phases	P1 (kW)	P2 (kW)	A	Rpm	Start	Ø	Cable (*)	Free passage	
①	DGX 50/2/G50V A0CT/50	400	3	-	0.37	1.1	2900	Dir	G 2"	A	38 mm
②	DGX 75/2/G50V A0CT/50	400	3	-	0.55	1.42	2900	Dir	G 2"	A	38 mm
③	DGX 100/2/G50V A0CT/50	400	3	-	0.88	2.3	2900	Dir	G 2"	A	38 mm
④	DGX 150/2/G50V A0CT/50	400	3	-	1.1	2.7	2900	Dir	G 2"	A	38 mm
⑤	DGX 200/2/G50V A0CT/50	400	3	-	1.5	3.5	2900	Dir	G 2"	A	38 mm

(*) A = H07RN-F 4G1 - 10 m

Models with horizontal DN65 PN10-16 flanged delivery port - 2 poles

Performances

	l/s	0	2	4	6	8	10	12	14
	l/min	0	120	240	360	480	600	720	840
	m ³ /h	0	7.2	14.4	21.6	28.8	36.0	43.2	50.4
① DGX 150/2/65 A0CM(T)50		9.1	8.5	7.7	6.7	5.5	4.1	2.5	
② DGX 200/2/65 A0CM/(T)50		9.6	9.1	8.4	7.5	6.4	5.1	3.7	2.0

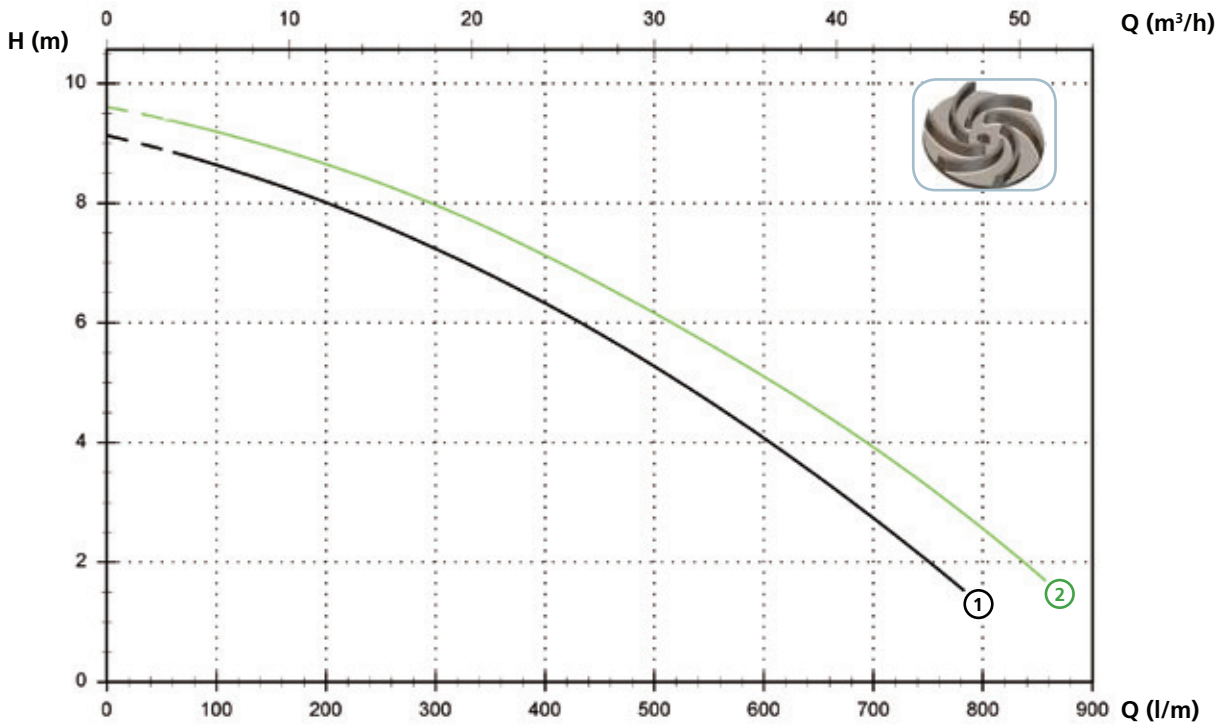

Technical data

	V	Phases	P1 (kW)	P2 (kW)	A	Rpm	Start	Ø	Cable (*)	Free passage
① DGX 150/2/65 A0CM/50	230	1	-	1.1	8.2	2900	Dir	DN65 PN10-16	A	50 mm
② DGX 200/2/65 A0CM/50	230	1	-	1.5	9.3	2900	Dir	DN65 PN10-16	A	50 mm

	V	Phases	P1 (kW)	P2 (kW)	A	Rpm	Start	Ø	Cable (*)	Free passage
① DGX 150/2/65 A0CT/50	400	3	-	1.1	2.7	2900	Dir	DN65 PN10-16	A	50 mm
② DGX 200/2/65 A0CT/50	400	3	-	1.5	3.5	2900	Dir	DN65 PN10-16	A	50 mm

(*) A = H07RN-F 4G1 - 10 m

DGX

Models with horizontal DN80 PN10 flanged delivery port - 2 poles

Performances

	l/s	0	2	4	6	8	10	12	14	16
	l/min	0	120	240	360	480	600	720	840	960
	m ³ /h	0	7.2	14.4	21.6	28.8	36.0	43.2	50.4	57.6
① DGX 200/2/80A A0CM(T)/50		8.1	7.5	6.8	5.9	5.1	4.3	3.5	2.7	1.9

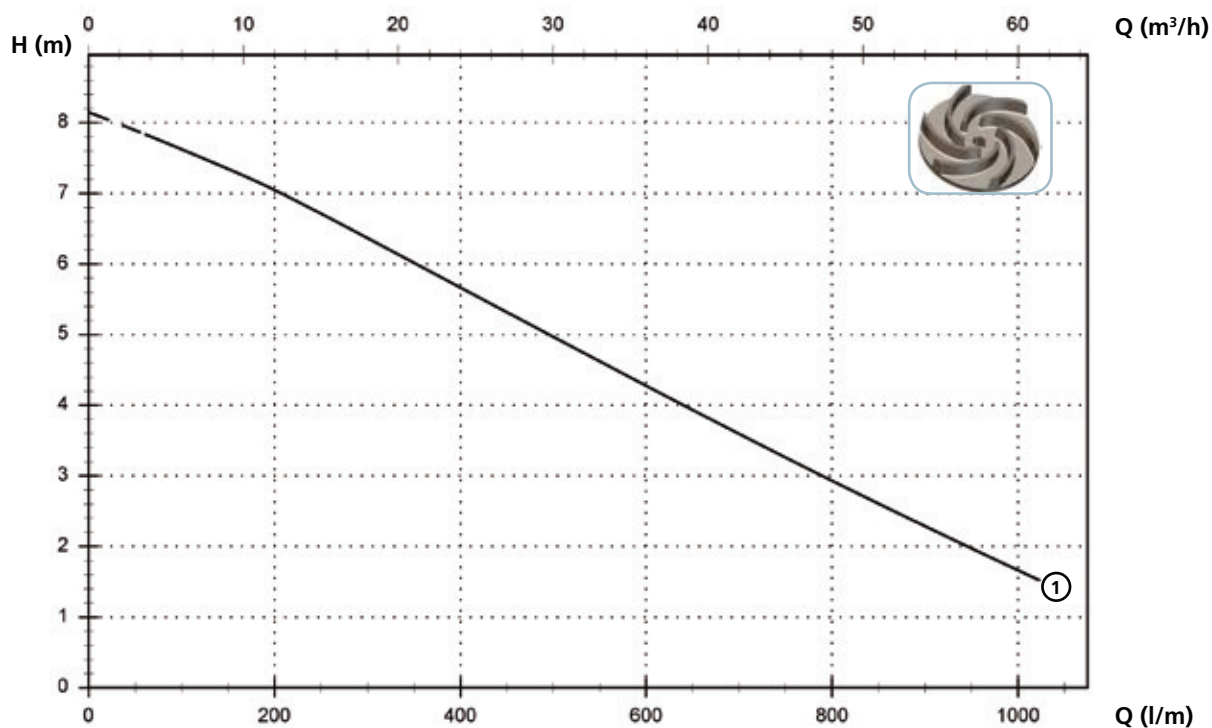

Technical data

	V	Phases	P1 (kW)	P2 (kW)	A	Rpm	Start	Ø	Cable (*)	Free passage
① DGX 200/2/80 A0CM/50	230	1	-	1.5	9.3	2900	Dir	DN80 PN10	A	60 mm
① DGX 200/2/80 A0CT/50	400	3	-	1.5	3.5	2900	Dir	DN80 PN10	A	60 mm

(*) A = H07RN-F 4G1 - 10 m

Models with vertical GAS 2" threaded delivery port - 4 poles

Performances

	l/s	0	1	2	3	4	5	6	7	8
	l/min	0	60	120	180	240	300	360	420	480
	m ³ /h	0	3.6	7.2	10.8	14.4	18.0	21.6	25.2	28.8
① DGX 100/4/G50V A0CM(T)/50		5.0	4.7	4.4	4.1	3.8	3.5	3.1	2.5	1.6

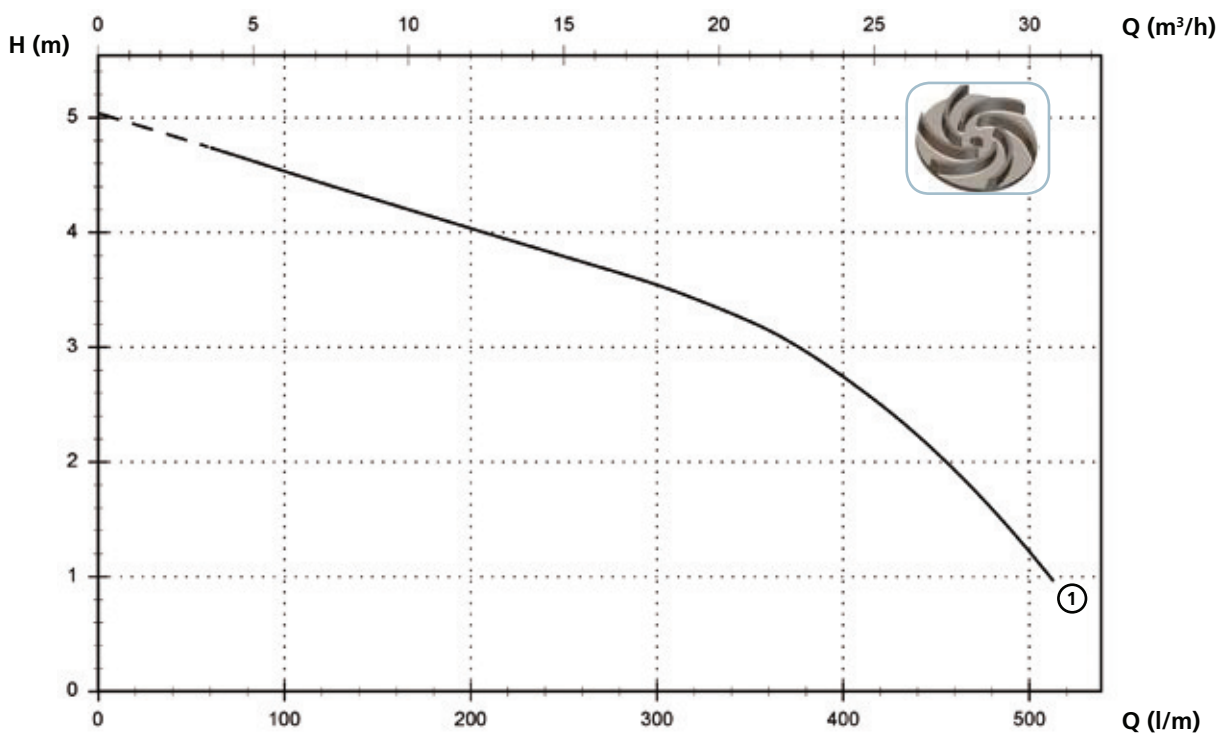

Technical data

	V	Phases	P1 (kW)	P2 (kW)	A	Rpm	Start	Ø	Cable (*)	Free passage
① DGX 100/4/G50V A0CM/50	230	1	-	0.63	4.5	1450	Dir	G 2"	A	20 mm

	V	Phases	P1 (kW)	P2 (kW)	A	Rpm	Start	Ø	Cable (*)	Free passage
① DGX 100/4/G50V A0CT/50	400	3	-	0.63	1.85	1450	Dir	G 2"	A	20 mm

(*) A = H07RN-F 4G1 - 10 m

DGX

Models with horizontal DN65 PN10-16 flanged delivery port - 4 poles

Performances

<i>l/s</i>	0	2	4	6	8	10	12
<i>l/min</i>	0	120	240	360	480	600	720
<i>m³/h</i>	0	7.2	14.4	21.6	28.8	36.0	43.2

① DGX 150/4/65 A0CM(T)/50	5.6	5.3	4.8	4.3	3.6	2.8	1.8
---------------------------	-----	-----	-----	-----	-----	-----	-----

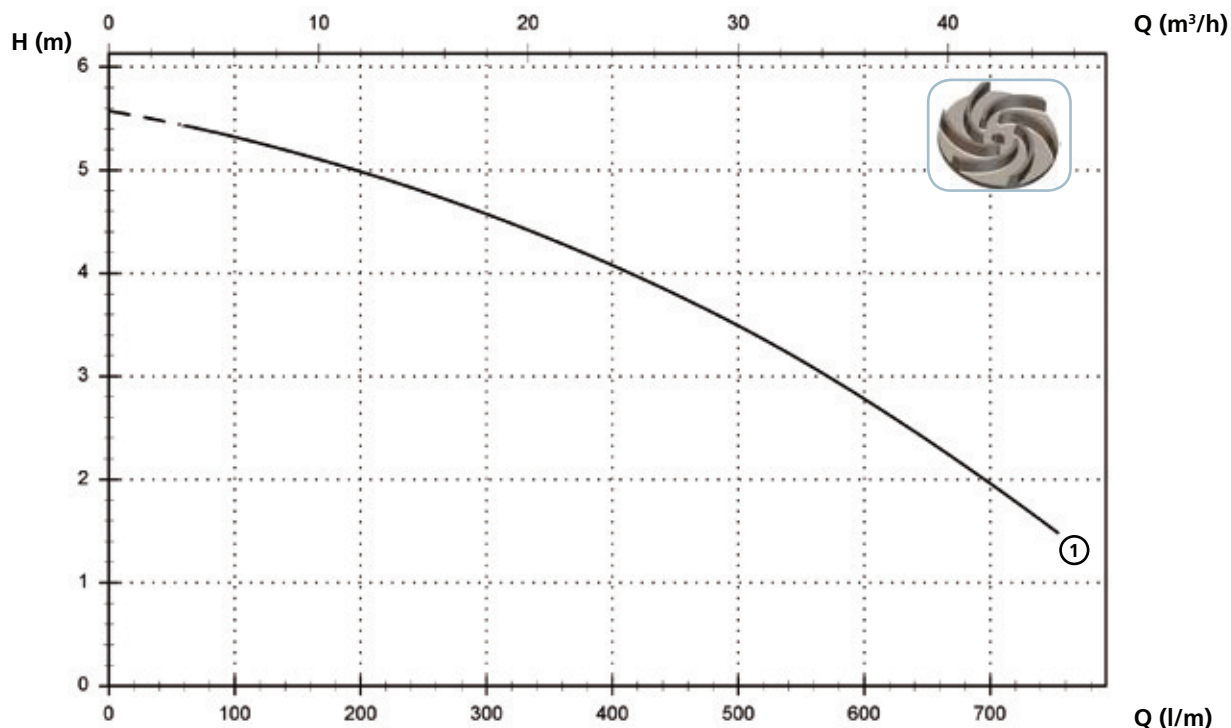

Technical data

	V	Phases	P1 (kW)	P2 (kW)	A	Rpm	Start	Ø	Cable (*)	Free passage
① DGX 150/4/65 A0CM/50	230	1	-	0.9	6.3	1450	Dir	DN65 PN10-16	A	45 mm
① DGX 150/4/65 A0CT/50	400	3	-	0.9	2.2	1450	Dir	DN65 PN10-16	A	45 mm

(*) A = H07RN-F 4G1 - 10 m

Models with horizontal DN80 PN10 flanged delivery port - 4 poles

Performances

	l/s	0	2	4	6	8	10	12	14	16	18
	l/min	0	120	240	360	480	600	720	840	960	1080
	m ³ /h	0	7.2	14.4	21.6	28.8	36.0	43.2	50.4	57.6	64.8
① DGX 150/4/80A A0CM(T)/50		5.1	4.8	4.5	4.0	3.5	3.1	2.6	2.1	1.6	1.1

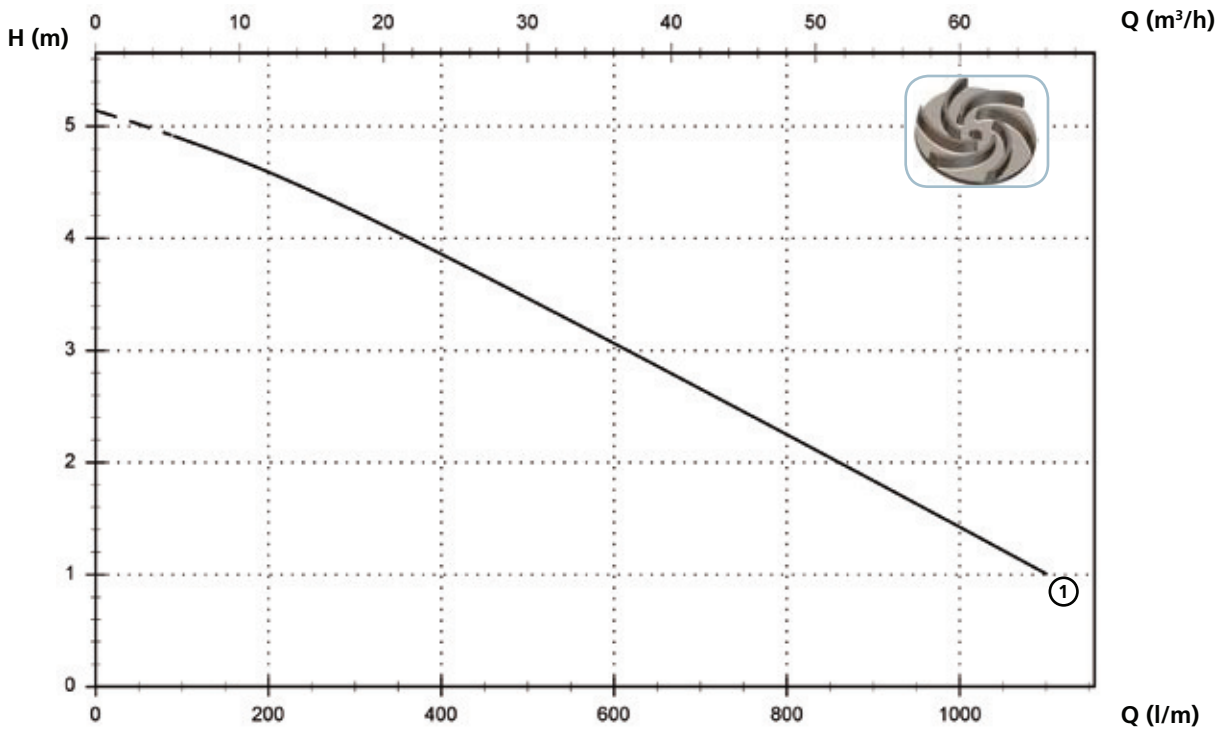

Technical data

	V	Phases	P1 (kW)	P2 (kW)	A	Rpm	Start	Ø	Cable (*)	Free passage
① DGX 150/4/80A0CM/50	230	1	-	0.9	6.3	1450	Dir	DN80 PN10	A	60 mm
① DGX 150/4/80A0CT/50	400	3	-	0.9	2.23	1450	Dir	DN80 PN10	A	60 mm

(*) A = H07RN-F 4G1 - 10 m

DGX

Versions available

(Key to versions on page 16)

	Electrical variants											Cooling				Mechanical seals			
	N A E	T C	T C D	T C D T	T C D G T	T C G	T C S T	T C S G T	T S	T R	T R G	N	CC CCE	FT	C G F T	2SIC	SICM	SICAL	2SICAL
DGX 50/2/G50V A0CM/50		●					●	●				●				●			
DGX 75/2/G50V A0CM/50		●					●	●				●				●			
DGX 100/2/G50V A0CM/50		●					●	●				●				●			
DGX 150/2/G50V A0CM/50		●					●	●				●				●			
DGX 200/2/G50V A0CM/50		●					●	●				●				●			
DGX 50/2/G50V A0CT/50	●											●				●			
DGX 75/2/G50V A0CT/50	●											●				●			
DGX 100/2/G50V A0CT/50	●											●				●			
DGX 150/2/G50V A0CT/50	●											●				●			
DGX 200/2/G50V A0CT/50	●											●				●			
DGX 150/2/65 A0CM/50		●					●	●				●				●			
DGX 200/2/65 A0CM/50		●					●	●				●				●			
DGX 150/2/65 A0CT/50	●											●				●			
DGX 200/2/65 A0CT/50	●											●				●			
DGX 200/2/80 A0CM/50		●					●	●				●				●			
DGX 200/2/80 A0CT/50	●											●				●			
DGX 100/4/G50V A0CM/50		●					●	●				●				●			
DGX 100/4/G50V A0CT/50	●											●				●			
DGX 150/4/65 A0CM/50		●					●	●				●				●			
DGX 150/4/65 A0CT/50	●											●				●			
DGX 150/4/80 A0CM/50		●					●	●				●				●			
DGX 150/4/80 A0CT/50	●											●				●			

Overall dimensions and weights

Models with vertical delivery port

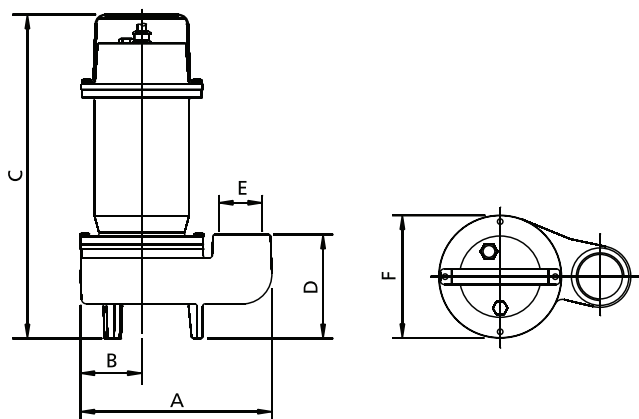

	A	B	C	D	E	F	kg
DGX 50/2/G50V A0CM(T)/50	225	75	360	120	G 2"	155	18
DGX 75/2/G50V A0CM(T)/50	225	75	360	120	G 2"	155	18
DGX 100/2/G50V A0CM (T)/50	245	80	410	130	G 2"	155	22
DGX 150/2/G50V A0CM (T)/50	245	80	410	130	G 2"	155	23
DGX 200/2/G50V A0CM (T)/50	245	80	410	130	G 2"	155	22
DGX 100/4/G50V A0CM (T)/50	245	80	410	130	G 2"	155	22

Measurements in mm

Overall dimensions and weights

Models with horizontal delivery port

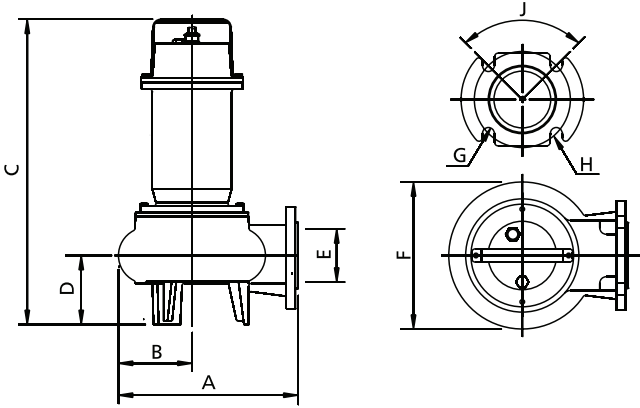

	A	B	C	D	E	F	G	H	J	kg
DGX 150/2/65 A0CM(T)/50	270	110	460	105	65	220	18	145	90°	28
DGX 200/2/65 A0CM(T)/50	270	110	460	105	65	220	18	145	90°	29
DGX 200/2/80 A0CM(T)/50	270	110	460	105	80	220	18	160	90°	33.5
DGX 150/4/65 A0CM(T)/50	270	110	460	105	65	220	18	145	90°	29
DGX 150/4/80 A0CM(T)/50	295	120	470	115	80	220	18	160	90°	33.5

Measurements in mm

Packaging dimension

	A	B	C
DGX 50/2/G50V A0CM(T)/50	385	225	245
DGX 75/2/G50V A0CM(T)/50	385	225	245
DGX 100/2/G50V A0CM(T)/50	475	285	235
DGX 150/2/G50V A0CM(T)/50	475	285	235
DGX 200/2/G50V A0CM(T)/50	475	285	235
DGX 100/4/G50V A0CM(T)/50	580	310	310
DGX 150/2/65 A0CM(T)/50	580	310	310
DGX 200/2/65 A0CM(T)/50	580	310	310
DGX 200/2/80 A0CM(T)/50	580	310	310
DGX 150/4/65 A0CM(T)/50	580	310	310
DGX 150/4/80 A0CM(T)/50	580	310	310

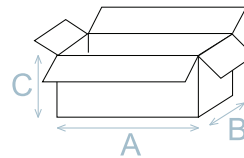

Dimension in mm

Installations available

